

Rice Farming Applicator Robot Control System Based on Radio Wave Communication Using Flysky Fs-iA6 Type Remote Control and Arduino Mega

Ridwan Siskandar^{1,✉}, Tineke Mandang², Wawan Hermawan², Irzaman³

¹ Computer Engineering Technology Study Program, College of Vocational Studies, IPB University, Bogor, INDONESIA.

² Department of Mechanical and Biosystem Engineering, Faculty of Agricultural Engineering and Technology, IPB University, Bogor, INDONESIA.

³ Department of Physics, Faculty of Mathematics and Science, IPB University, Bogor, INDONESIA

Article History:

Received : 07 September 2024

Revised : 15 April 2025

Accepted : 28 April 2025

Keywords:

Agricultural applicator robot control system;
Arduino mega;
Bevel gear;
Boom sprayer;
Remote control

Corresponding Author:

✉ ridwansiskandar@apps.ipb.ac.id
(Ridwan Siskandar)

ABSTRACT

This research focuses on designing a control system for pesticide applicator robots on rice plants. Control is carried out via radio wave communication using a transmitter-receiver (Flysky FS-iA6 2.4 GHz). The remote can control the robot wheel (forward, backward and turn), boom sprayer (raise-fall and open-close), and spray pump. The research method is carried out using the waterfall model because it is under the needs that require a sequential flow in the process. The test results show that the use of a bevel gear gearbox can increase the torque value up to 3 times. The use of 4 electric motors further increases the stability of the robot's movement (RPM and torque) when given the maximum load of the robot. The boom sprayer successfully opens-closes and fluctuates smoothly at the optimum value of PWM 50 and voltage 2.35. The time required for the boom sprayer to open-close, and rise-fall is 30 s. The relay which functions as a switch is successfully controlled, so that the pump can be activated and deactivated in mode 2 at the input. Transmitter-receiver communication test was successfully carried out. Transmitter-receiver communication is capable of up to a distance of < 150 m. Input mode 1 on the transmitter successfully controls the boom sprayer. Input mode 2 successfully controls the motion of the wheels and pump.

1. INTRODUCTION

According to BPS, the number of farmers in Indonesia has significantly decreased in recent years. For example, from 2013 to 2021, there was a decline of about 10-15% in the number of registered farmers. The uncertainty of commodity prices and high production costs are the main reasons farmers are leaving their profession. Many are shifting to other sectors that are considered more profitable. In addition, the lack of access to modern technology and efficient farming techniques has also made the farming profession less appealing to the younger generation. Strengthened, the development of agricultural mechanization technology, especially applicator machine mechanization, is very interesting and has been widely studied by previous researchers (Askari *et al.*, 2017; Bahlol *et al.*, 2020; Chaitanya *et al.*, 2020; Kotkar *et al.*, 2021; Karmokar *et al.*, 2020; Lienkov *et al.*, 2020; Macák *et al.*, 2011; Mahmud *et al.*, 2021; Mishra & Behra, 2020; Nosirov *et al.*, 2020; Patel, 2016; Petranský *et al.*, 2003; Sánchez-Hermosilla *et al.*, 2021; Sobotka *et al.*, 2007; Su *et al.*, 2020; Tkáč *et al.*, 2005; Yu & Song, 2023). Moreover, until now the importance of efficiency and effectiveness of activities in spraying pesticides on rice is very well recognized by farmers. Ahmad *et al.* (2021); Kim *et al.* (2017); Yarpuz-Bozdogan (2018), in their research revealed that traditional pesticide application requires paying attention to health risks during the spraying process. On the other hand, Kim *et al.* (2017), revealed that the traditional pesticide spraying process has been studied in terms of pesticide exposure which is associated with various diseases.

Apart from the health risks that must be taken into account, [Ahmad *et al.* \(2021\)](#) revealed that traditional pesticide spraying has not been able to increase efficiency and effectiveness in increasing productivity and performance of farming businesses. This is indicated by the length of time the spraying process takes, the use of costs and the use of energy.

The presence of drone technology in Indonesian agriculture is an alternative solution to the modernization of agricultural mechanization. Drones are here as a solution for completing the pesticide spraying process, even though the price of drones on the market is still very expensive ([Ahmad *et al.*, 2020](#); [Andrasto *et al.*, 2021](#); [Devi *et al.*, 2020](#); [Mogili & Deepak, 2018](#); [Wang *et al.*, 2019a](#); [Wang *et al.*, 2019b](#)). [Andrasto *et al.* \(2021\)](#); [Mogili & Deepak \(2018\)](#) revealed in their research that drones have a time-saving impact in the pesticide spraying process when compared to traditional spray methods. [Devi *et al.* \(2020\)](#); [Mogili & Deepak \(2018\)](#), stated that drones are the newest technology in this decade with their advantages, namely: the spraying process can be carried out via navigation with GPS coordinates, can reduce the amount of pesticide liquid used, can measure wind speed and humidity air, and can reduce deviations in uniform spraying which has an impact on cost savings. However, [Ahmad *et al.* \(2020\)](#); [Devi *et al.* \(2020\)](#); [Wang *et al.* \(2019a\)](#); [Wang *et al.* \(2019b\)](#), in their research revealed several shortcomings that need to be considered in using drone technology as a pesticide applicator tool, including: price agricultural drones are still soaring high, climatic factors that suddenly change can result in deviations in droplet accuracy and range distance accuracy, the influence of determining parameters (flight speed; flight height; droplet diameter coverage; amount of spray deposition) requires a more in-depth study regarding deposition target (target zone and non-target zone).

The presence of challenges, ranging from labor shortages to the need to improve agricultural production efficiency, has led to the emergence of agricultural robotics and Arduino-based automation systems as innovative solutions that can revolutionize food production. With the ability to perform routine tasks such as spraying, this technology enables farmers to save time and resources while increasing productivity ([Shamsiri *et al.*, 2018](#)).

In addition, the use of robotics can help address labor shortages, which often pose serious problems in many areas, as indicated by BPS data from 2013 to 2021 showing a decline of about 10-15% in the number of farmers. Robots can work continuously, even in unfavorable weather conditions, ensuring that tasks are carried out effectively. Arduino-based automation systems also enable real-time data collection on soil conditions and plant health, providing valuable insights for better agricultural management ([Mumtaz *et al.*, 2018](#); [Gong *et al.*, 2020](#)).

The application of this technology also supports more sustainable farming practices. By minimizing the use of water and pesticides, and implementing more environmentally friendly techniques, agricultural robotics can contribute to the sustainability of ecosystems. Additionally, this technology opens up opportunities for the younger generation to engage in innovation, enhancing their skills in programming and system design, while creating new solutions to existing challenges. Thus, this transformation is not only crucial for farmers but also for global food security in the future.

Referring to the research that has been carried out by previous researchers, the researcher has reviewed and conducted research related to the Rice Farming Applicator Robot Control System Based on Radio Wave Communication Using Flysky FS-iA6 Type Remote Control and Arduino Mega. The focus of this research is to design a rice applicator robot and its control system using a transmitter-receiver (Flysky FS-iA6 2.4 GHz). The remote can control the movement of the robot wheel (forward, backward and turning), the sprayer boom (up-down and open-close) and the spray pump. The aim of this research is to create a rice farming applicator robot that can be controlled remotely. The novelty of this research is in the pesticide applicator machine for lowland rice with remote control.

2. RESEARCH MATERIALS AND METHODS

The research was conducted in May 2022 - August 2023 at the Hardware Laboratory, Computer Engineering Technology Study Program, Vocational School of IPB and in Bojong Village rice fields, Cilimus District, Kuningan Regency, West Java Province. The functional design concept for the requirements for tools and materials used is shown in Table 1. The selection of hardware shown in Table 1 is based on the needs in the development of the robot. The chosen components have been analyzed and are readily available, ensuring that they can be easily sourced if replacement parts are needed for future maintenance of the robot.

Table 1. The concept of functional design for tools and materials

No	Materials and tools	Volume	Unit	Describe
1	Flysky FS-IA6 type remote control	1	unit	As a transmitter and input for controlling wheel motion, boom sprayer motion, and pumps
2	FS-IA6 2.4GHz	1	unit	As a receiver that can catch the signal from the transmitter. The next signal will be processed by Arduino Mega
3	Arduino Mega	1	unit	As a data/signal processing that is sent from the input
4	350 watt 24 VDC electric motor brand Kits Guru MY1016Z3	4	unit	As a wheel drive (output)
5	BTS 7960 type motor driver	9	unit	As a PWM (Pulse Width Modulation) regulator of electric motors. BTS can issue currents up to 43A
6	24 VDC Motor 555 Metal Gear Gearbox 90 RPM High Torque (brand Takanawa0	4	unit	As a sprayer boom drive (output)
7	Linear Actuator 500 mm 12 VDC 1500 N 50 cm motorized 150 kg	2	unit	As a front-wheel drive to turn (output)
8	Pump 12 VDC 250 PSI Big Pump N2828 120 Watt (brand NIKUMA)	3	unit	Pumping and flowing pesticide liquid to each nozzle (output)
9	Nozzles	20	unit	Pesticide drains
10	5 VDC relays	3	unit	As a pump on/off switch
11	Robot frame mechanics and control systems	1	pack	Using holo iron 4x4 cm, 4x2 cm, 3x3 cm, ½ inch pipe and angle iron. The mechanical frame of the robot is divided into 3 main parts, namely: the legs/wheels, the boom sprayer, and the body.

2.1. Design

The design is carried out to facilitate the business process of making applicator robots and their control systems. The design stages in this study consist of four parts, namely:

2.1.1. Block Diagram Design

Block diagrams are made to map work processes on robots and systems that are made. More details are shown in Figure 1. In principle, the transmitter will send data which is then received by the receiver via radio wave communication, then the data is sent to the micro-controller. Arduino Mega will process the received data and order the output to work according to the input command received by Arduino Mega.

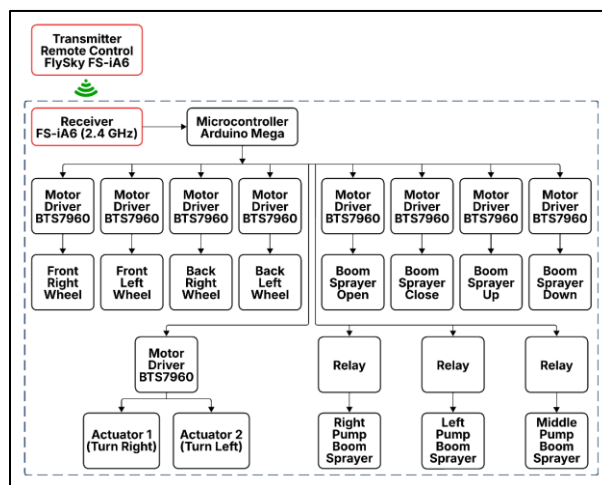

Figure 1. Block diagram of the rice farming applicator robot control system

The operation of the remote-control system on the Robot is more clearly illustrated in Figure 2 and Table 2. Both provide details about the remote-control instructions and the functions of these instructions. The remote control is divided into two modes: Mode 1 for controlling the movement of the boom sprayer, and Mode 2 for controlling forward and backward movement, turning, and the on-off function of the pump.

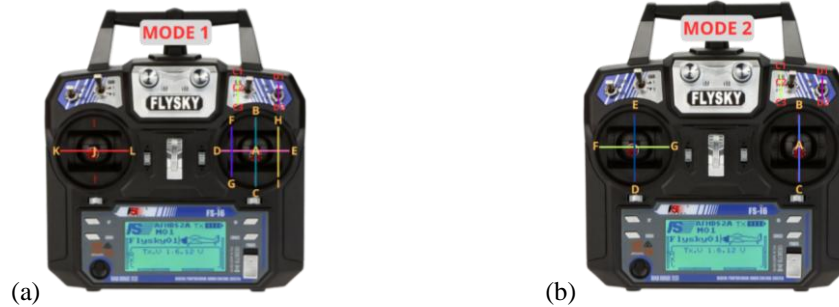

Figure 2. Remote control instructions: (a) mode 1; (b) mode 2

Table 2. Functions of remote-control instructions

Mode	Controlled	Description
Mode 1 (Switch Position C2)	Boom Sprayer: Open-Close	a. If the stick is at point J, then no instructions are given to the boom sprayer. b. If the stick moves from point J to point K, then: <ul style="list-style-type: none"> • If switch D1 is activated, the right boom sprayer will open. • If switch D2 is activated, the right boom sprayer will close c. If the stick moves from point J to point L, then: <ul style="list-style-type: none"> • If switch D1 is activated, the left boom sprayer will open. • If switch D2 is activated, the left boom sprayer will close.
	<i>Boom sprayer:</i> up-down	a. If the stick is stationary at point A, then no instructions are given to the boom sprayer. b. If the stick moves from point A to point B, then both boom sprayers will rise. c. If the stick moves from point A to point C, then both boom sprayers will lower. d. If the stick moves from point A to point D, then no instructions are given to the boom sprayer. e. If the stick moves from point D to point F, then the left boom sprayer will rise. f. If the stick moves from point D to point G, then the left boom sprayer will lower. g. If the stick moves from point A to point E, then no instructions are given to the boom sprayer. h. If the stick moves from point E to point H, then the right boom sprayer will rise. i. If the stick moves from point E to point I, then the right boom sprayer will low
Mode 2 (Switch Position C3)	Electric Motor 350 W 24 V: Forward-Reverse	a. If the stick moves from point A to point B: <ul style="list-style-type: none"> • If the throttle stick is at point D, then speed is 0% (PWM = 0). • If the throttle stick is at point E, then speed is 100% (PWM = 255). b. If the stick moves from point A to point C: <ul style="list-style-type: none"> • If the throttle stick is at point D, then speed is 0% (PWM = 0). • If the throttle stick is at point E, then speed is 100% (PWM = 255).
	12 DC Actuator	a. If the stick moves from the center to point F, the steering wheel will turn to the left. b. If the stick moves from the center to point G, the steering wheel will turn to the right.
	12 DC Pump	a. If switch D1 is active, then the pump is off. b. If switch D2 is active, then the pump is on.

2.1.2. Flowchart Design

Figure 3 shows the flow diagram of the rice farming robot applicator control system. When the operator activates the main electrical button, all components are ready to be controlled. The wheels will function according to the input given. The applicator works if the sprayer boom is open. Likewise for controlling the sprayer boom up and down.

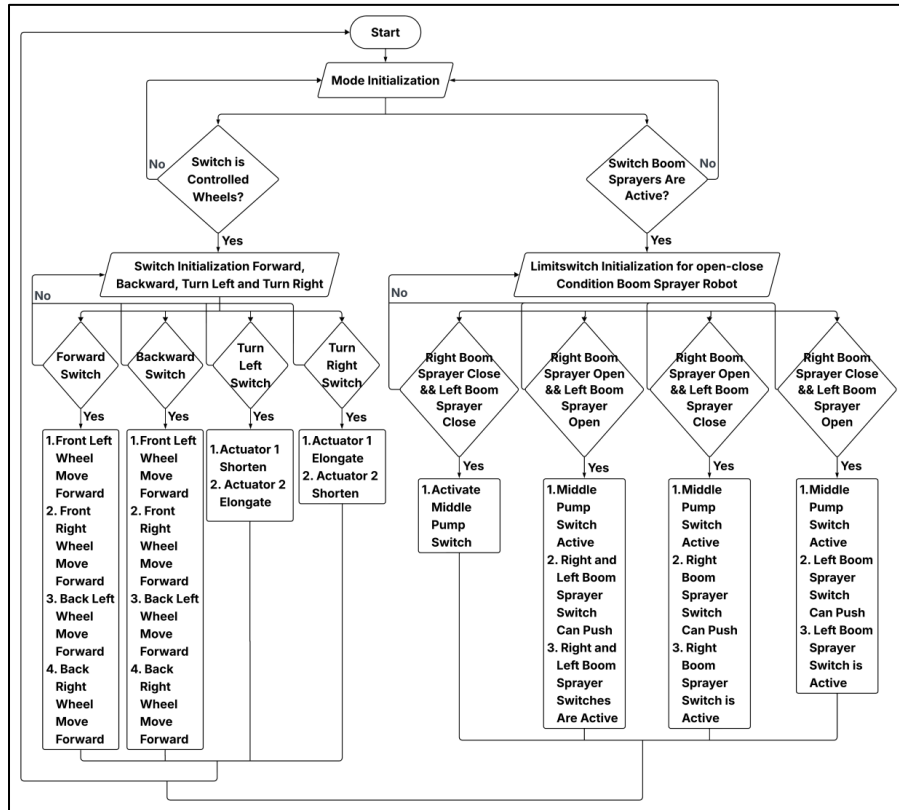
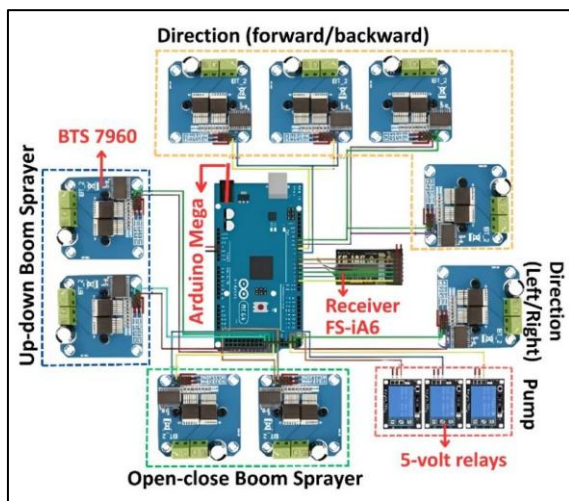

Figure 3. Flowchart of the rice farming applicator robot control system

2.1.3. Hardware and Software Design

The hardware design consists of four control button functions, namely control for the movement of the robot wheel, opening and closing and rising and falling of the sprayer boom and on-off of the applicator pump. The components used are 9 BTS7960 motor drivers, 3 relays, 1 Arduino Mega, 8 limit switches and 1 Flysky FS-iA6 2.4 GHz package.



(a)

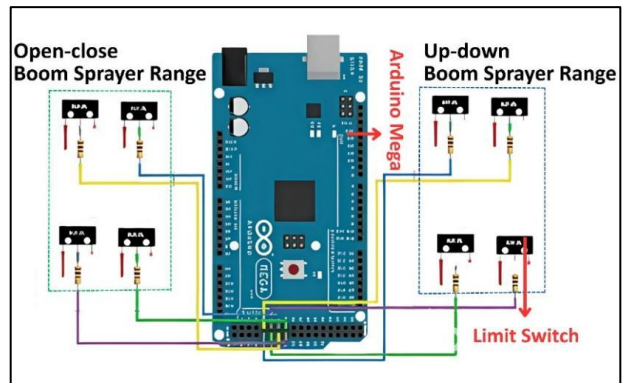

(b)

Figure 4. The hardware design of the farming applicator robot control system: (a) Wheel control, boom sprayer, and pump; (b) Limit switch for boom sprayer

In more detail, the design of the control system hardware is shown in Figure 4. Figure 4(a) illustrates that the Arduino Mega functions as a data or signal processor. The data or signals received from the FS-iA6 receiver are processed by the Arduino Mega. Subsequently, the Arduino Mega commands the BTS 7960 to activate according to the received inputs (such as up-down/open-close for the boom sprayer; forward-backward/left-right for direction; on/off for the pump). Figure 4(b) explains the functionality of the hardware components that interrupt the movement of the open-close/up-down boom sprayer. This is necessary based on the minimum and maximum range for the open-close/up-down operation of the boom sprayer.

Meanwhile, in software design, the programming language used is the C programming language. Of course, the program code is adapted to the hardware design, which consists of five parts, namely: pin initialization, receiver control, wheel control, boom sprayer control and pump control.

2.1.4. Robot Mechanical Structural Design

Structural design was carried out to determine the shape, dimensions and materials of each component required. More details were shown in Figure 5.

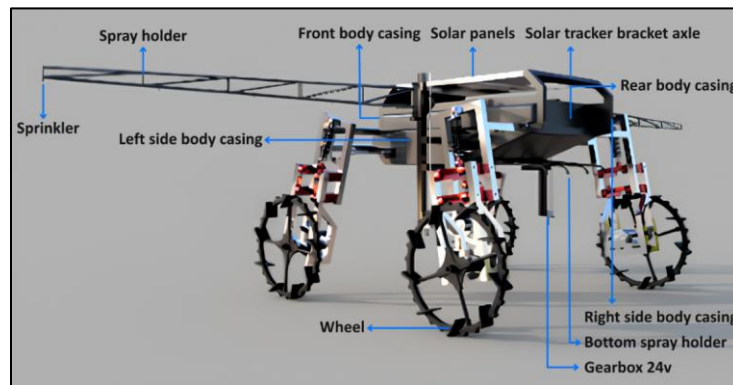

Figure 5. Mechanical structural design of the rice farming applicator robot

2.2. Implementation and Testing Stage

The implementation stage is the integration of hardware and software devices. The success of the implementation phase is measured from the test results. Testing is carried out to determine the performance of hardware devices, software devices, and the integration between the two. Testing on the applicator robot control system consists of robot mechanical functional testing, transmitter-receiver range testing, hardware testing, and robot control system integration testing.

3. RESULTS AND DISCUSSION

3.1. Robotic Mechanical Functional Testing

Mechanical functional was tested to find out whether the framework of the robot is functioning properly or not to be implemented. Tests were carried out on the leg frame, wheel gear box, boom sprayer and turning system.

3.1.1. Leg Frame

The leg frame is made with the main material which is composed of rectifier suspension, upper fork, lower fork and suspension. The suspension functions as a support for the robot's body, while the suspension rectifier has an important role in aligning the lower leg and the suspension to remain vertical. The wheelbase is more clearly shown in Figure 6. The wheel legs can support a weight of 195 kg. The suspension used is a mono shock type which has a spring constant value of $k = 2500$ N/m. The robot that is made has a construction of 4 pieces of suspension, so the deflection value of the spring against the mass of the load is 0.02 m. This spring deflection value is used to determine the distance between the upper fork and lower fork connected by the suspension rectifier.



Figure 6. The wheel frame of the rice farming applicator robot

3.1.2. Motor Gearbox

In this research, the wheel rotation system is assisted by a bevel gear model. Bevel gears are used to efficiently transmit power between shafts that intersect each other at different angles. This allows robotic machines to transfer power with little energy loss caused by friction and heat. The results of the rotation (RPM) test against the load (without bevel gear and with bevel gear) are shown in Figure 7. In this study the bevel gear ratio used was 1:3, with a thread count of 18:54. Thus, the torque generated after adding bevel gear to 3.33 Nm (3x than before).

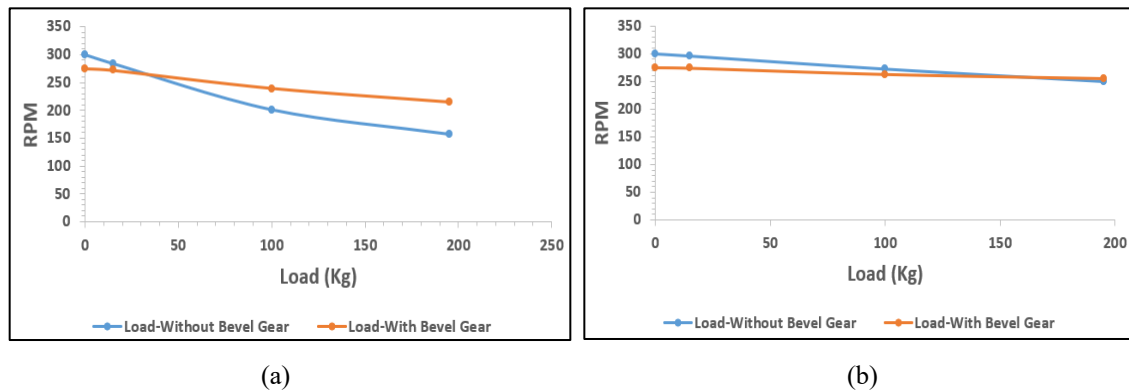

Figure 7. Results of the rotation (RPM) test on the load (without and with bevel gear): (a) one motor, and (b) four motors

3.1.3. Boom Sprayer

The sprayer boom is made to open and close and go up and down. The sprayer boom is connected to the sprayer rail. The boom sprayer test results are shown in Table 3. Table 3 explains that the mechanical functional testing of the boom sprayer is functioning properly.

Table 3. The results of the boom sprayer mechanical test

No	Sprayer boom condition	Motor Drive	Iron screw	Spayer Roller	Vibration
1	Closed-Open	On	Rotating Motion	Smooth move	< 3°
2	Closed-Open	Off	Not Spinning	Not moving	There isn't any
3	Ups and down	On	Rotating Motion	Smooth move	< 3°
4	Ups and down	Off	Not Spinning	Not moving	There isn't any

3.1.4. Turning System

Turning system testing is carried out on wheel conditions (straight and turning). The main mover in the turning system is the actuator. The actuator is powered by 12 volts. The mechanical weight of the legs and wheels is 30 kg each. The

test results are shown in Table 4. The results of the mechanical testing of the turning system were successful. The turning system is capable of turning and returning to the starting position with 12volt power. The angle formed is 45° when turning and 0° when straight.

Table 4. The results of the mechanical testing of the wheel turning system

No	Wheel Condition	Actuator 1 (cm)	Actuator 2 (cm)	Left Wheel Angle (°C)	Front Wheel Angle	Time Required (s)
1	Straight	15	15	0	0	0
2	Turn right	0	30	45	45	10
3	Turn left	30	0	45	45	10

3.2. Transmitter-Receiver Range Testing

The robot was developed with a remote-control mode assisted by a remote controller (FS-iA6). FS-iA6 is capable of communicating remotely within a range of less than 150 m (without obstacles) based on radio wave communication. The transmitter-receiver communication test results are shown in Table 5. Table 5 explains that communication between the transmitter and receiver shows a significant difference between conditions with and without interference, as well as the distance variable. In an open area with interference, out of seven tests conducted at distances ranging from 25 m to 150 m, six of them successfully received data, resulting in a success rate of 85.71%. This testing indicates that at a distance of 125 m, communication can still occur effectively; however, at a distance of 150 m, no data was received by the receiver. Conversely, in conditions without interference, all tests were successful, yielding a success rate of 100%. This demonstrates that the transmitter and receiver can communicate effectively without external disruptions. Testing at greater distances, such as 125 m and 150 m, confirms that the system continues to function well under ideal conditions. Overall, these results emphasize that interference has a significant impact on communication capability, and conditions without interference provide optimal results at all tested distances.

Testing is carried out to ensure whether the maximum range of the received signal is stable. The analyzed results are in the form of "distance" data. Table 5 shows the maximum operating distance of the transmitter-receiver performance. The tests are conducted in an open area (with/without interference). The tests with interference are conducted with the remote (transmitter) positioned approximately 4 m away from a high-voltage power pole. The error results (with interference) at a distance of 150 m indicate that the frequency wave signal is decreasing, causing interruptions in transmitter-receiver communication. In contrast, the results of the tests conducted without interference show that the communication range between the transmitter and receiver at 150 m remains uninterrupted.

Table 5. Results of transmitter and receiver communication tests

Test to-	Distance (m)	In an Open Area (With Interference)	In an Open Area (Without Interference)
1	25	Data received	Data received
2	50	Data received	Data received
3	75	Data received	Data received
4	100	Data received	Data received
5	125	Data received	Data received
6	147	Data received	Data received
7	150	No data received by the receiver	Data received

In an open area (with interference), the potential for electromagnetic noise significantly impacts the performance of the Flysky FS-iA6 remote radio waves, especially since the system relies on radio signal transmission that can be disrupted by various external factors. The Flysky FS-iA6 operates at a frequency of 2.4 GHz, meaning that high-voltage power sources can create electromagnetic interference that disrupts radio communication. This results in signal reflections that collide, affecting the loss of effective range. Consequently, at 150 m, the frequency wave signal diminishes, leading to a breakdown in transmitter-receiver communication (generally, the Flysky FS-iA6 is capable of operating up to a range of 300 m) in an open area without interference.

The signal used in this control system is radio waves, which may face disturbances related to control, including response delays, safety issues, and the possibility of unwanted actuation, especially in weak signal situations. Control delays can occur if the signal from the transmitter to the receiver is interrupted or experiences latency, resulting in unpredictable movements of the controlled model. However, in this robot, such issues are not urgent, as the robot operates on the ground, unlike aircraft models that could fall and pose risks to nearby people or damage property if control delays occur.

Additionally, unwanted actuation can be managed by the robot. In weak signal conditions, the transmitter may misinterpret the data received, causing components to move without clear commands. Therefore, the robot has implemented mitigation steps, such as ensuring that the control software has logic capable of recognizing and effectively responding to weak signal situations (through captured voltage values) and dividing remote control instructions into two modes, thereby reducing communication noise between the transmitter and receiver.

3.3. Hardware Testing

Hardware testing for output voltage was carried out on the BTS 7960 motor driver circuit. The aim was to determine the performance of the electric motor based on the robot load. More specifically, the results of the PWM test for electric motors against output voltage at a load of 100 kg and 195 kg are shown in Figure 8. Measurements of PWM speed versus output voltage on asphalt for load variations show the same pattern, namely the greater the PWM value used, the greater the output voltage value. The output voltage generated by the load is 195 kg lower than other loads. This is because when the load increases, more current flows through the internal impedance, causing a higher voltage drop. If the test is carried out on loose and wet soil media, the output voltage will decrease. This is due to the increased load (external force factor). More specifically, the results of measurements on loose and wet soil are shown in Figure 9.

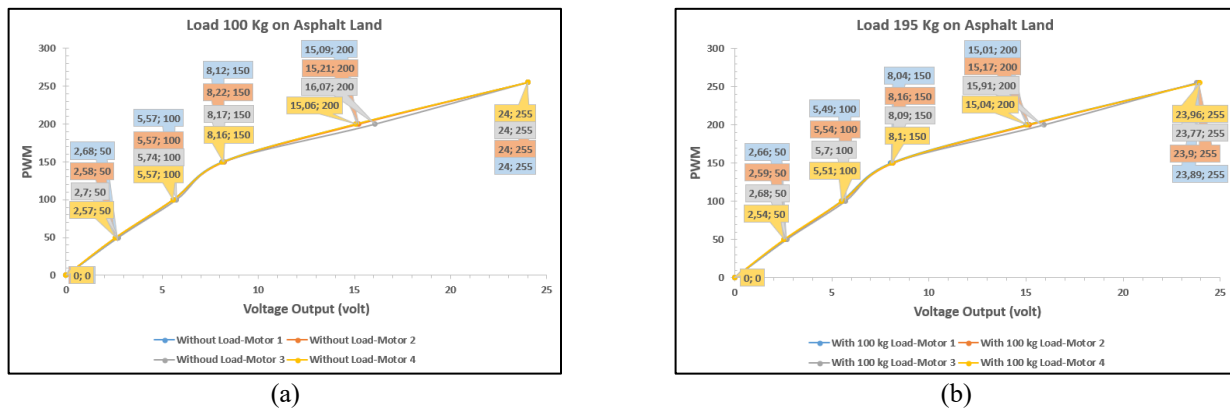

Figure 8. Output voltage of the PWM value against the robot load on asphalt land: (a) load 100 kg; (b) load 195 kg

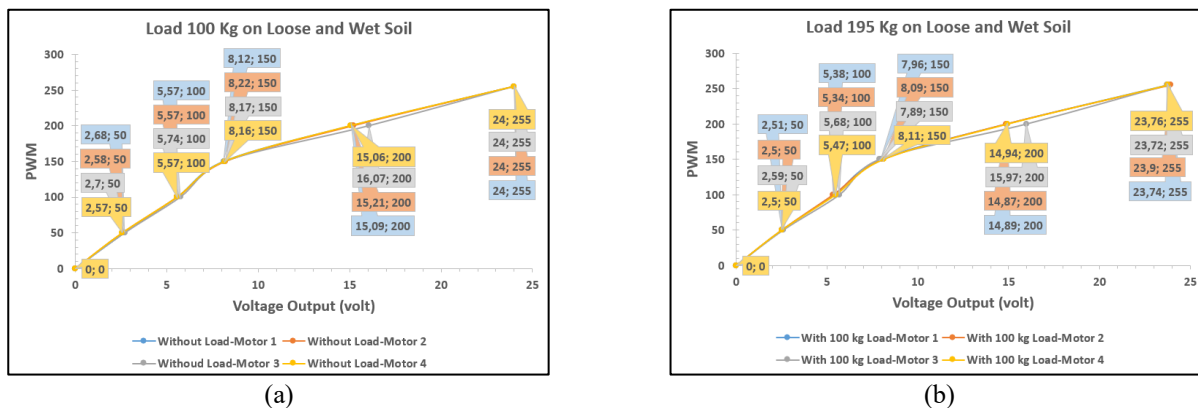

Figure 9. Output voltage of the PWM value against the robot load on loose and wet soil: (a) load 100 kg; (b) load 195 kg

Table 6. Test results for the optimum PWM value of the DC 555 motor for the boom sprayer

No	PWM	Voltage (volt)	Time for the ups and downs (s)	Time to open and close (s)	Description
1	0	0	Not moving	Not moving	Not moving
2	50	2.35	30	30	<i>smooth</i>
3	100	4.71	23	20	Smooth enough
4	150	7.06	20	19	Smooth enough
5	200	9.41	19	17	Not smooth
6	255	12	18	16	Not smooth

The test data of voltage versus PWM in Figures 8 and 9 can be used to confirm the effectiveness of electric motor movement significantly. PWM functions as a speed controller for the electric motor by varying the ratio of on and off time of the signal. The higher the average voltage received by the motor, the greater the duty cycle of the PWM signal, leading to increased speed. By collecting voltage data at various PWM levels, a relationship between duty cycle and average voltage is established. A linear graph of voltage and PWM shows that the motor operates well and is responsive to changes in PWM. The data in Figures 8 and 9 represent the averages from three repeated tests. The accuracy values obtained are 99.80% for Figure 8(a), 99.74% for Figure 8(b), 99.80% for Figure 9(a), and 99.58% for Figure 9(b). Table 6 explains that the optimum PWM value suitable for use for sprayer booms going up and down and opening and closing is 50. The test results show that there is smooth movement in the thread axle if the PWM is set at a value of 50. The length of the threaded iron used as the boom driver/pusher sprayer is 100 cm.

Another electronic circuit test is the circuit test for the pump. The pump is connected to a 5volt relay. This test is carried out to determine whether the relay functions properly when the coil is given a voltage of 5 volts and 0 volts. When the relay condition is "NO" (0 volt), the relay is in the off state, so the pump is not active. On the other hand, when the relay condition is "NC" (5 volts), the relay is on, so the pump is active.

3.4. Field Performance Testing of the Robot

This testing is conducted to evaluate the field performance of the pump applicator on the robot concerning the liquid distribution pattern produced by the sprayer while the applicator robot operates at specific forward speeds and vibrations. The testing is carried out dynamically. The vibrations generated during robot operation and when the sprayer pump is active are less than 5°. Figure 10 shows liquid distribution pattern formed when synchronized with the forward speed.











Figure 10. Liquid distribution pattern synchronized with forward speed

3.5. Testing the Integration of the Paddy Farming Applicator Robot Control System

This test was carried out to ensure that the control system integration could be applied to the rice farming applicator robot. Testing was carried out for robot conditions (forward, backward); boom sprayer (open-close and up-down); and pump (on, off). More detailed test results of the robot applicator control system integration are shown in Table 7.

Table 7. The results of the applicator robot control system integration test

No	Test Name	Integration Input and Output	Describe
1	Proceed		Succeed
2	Back off		Succeed
3	Open the sprayer boom		Succeed
4	Close the sprayer boom		Succeed
5	Raise the sprayer boom		Succeed
6	Lowering the sprayer boom		Succeed
7	Turn right		Succeed
8	Turn left		Succeed
9	Applicator pump on		Succeed

The testing was conducted at a sprayer boom height of 40 cm, where the average width between rice rows is 100 cm. The applicator robot took 42.86 s to spray an area of 24 m, with a sprayer boom span of 6 m. Thus, the spraying speed is 4.48 L/min. The application volume is 224 L for an area of one hectare. The theoretical field capacity is 1.20 ha/h, the effective field capacity is 1.21 ha/h, and the field efficiency is 99.83%.

4. CONCLUSION

The application of a rice farming applicator robot control system based on radio wave communication using a remote-control type Flysky FS-iA6 and Arduino mega has been successfully carried out. Robot mechanization with a total weight filled with liquid is 195 kg. The use of a bevel gear gearbox can increase the torque value up to 3 times, even though the RPM decreases. The use of 4 electric motors further increases the stability of the robot's movement (RPM and torque) when given the maximum load of the robot. The boom sprayer successfully opens and closes and fluctuates smoothly at the optimum value of PWM 50 and voltage 2.35. The time required for the boom sprayer to open and close and rise and fall is 30 s. The relay which functions as a switch is successfully controlled, so that the pump can be activated and deactivated in mode 2 at the input. Transmitter-receiver communication test was successfully carried out. Transmitter-receiver communication is capable of up to a distance of < 150 m. With this, the robot provides a positive impact on the social welfare of farmers, particularly in terms of their health. This robot also emphasizes contributions to a user-friendly robotic control system, agile wheel movement, and environmental friendliness. This aligns with the SDGs 2, 6, 12, and 13 related to environmentally friendly agricultural technology, supporting future research in agriculture towards full autonomy or IoT integration. Next, the development of the robot needs to be enhanced in the maneuvering system, particularly in the turning mechanism. The use of a skid steering motion system can be considered to increase agility during turns. This approach allows the robot to rotate more quickly and efficiently, improving its navigation capabilities in narrow or complex terrains.

ACKNOWLEDGMENTS

We gratefully acknowledge the funding from Hibah Program Kompetitif Nasional Skema Penelitian Disertasi Doktor (PDD) with grant number 15889/IT3.D10/PT.01.02/P/T/2023, dated 13 April, 2023, Kementerian Pendidikan, Kebudayaan, Riset, dan Teknologi Republik Indonesia.

REFERENCES

- Ahmad, F., Khaliq, A., Qiu, B., Sultan, M., & Ma, J. (2021). Advancements of spraying technology in agriculture. *IntechOpen*. <https://doi.org/10.5772/intechopen.98500>
- Ahmad, F., Qiu, B., Dong, X., Ma, J., Huang, X., Ahmed, S., & Ali Chandio, F. (2020). Effect of operational parameters of UAV sprayer on spray deposition pattern in target and off-target zones during outer field weed control application. *Computers and Electronics in Agriculture*, *172*, 105350. <https://doi.org/10.1016/j.compag.2020.105350>
- Andrasto, T., Arief, U.M., Subiyanto, Sukanta, S., Sulistyawan, V.N., Sarwono, E., Alfian, A.A., Wicaksono, P., Amelia, P.N., & Putra, A.D.H. (2021). The effectiveness of disinfectant spraying based on drone technology. *IOP Conference Series: Earth and Environmental Science*, *700*(1), 012012. <https://doi.org/10.1088/1755-1315/700/1/012012>
- Askari, M., Shahgholi, G., & Abbaspour-Gilandeh, Y. (2017). The effect of tine, wing, operating depth and speed on the draft requirement of subsoil tillage tines. *Research in Agricultural Engineering*, *63*(4), 160–167. <https://doi.org/10.17221/4/2016-RAE>
- Bahlol, H.Y., Chandel, A.K., Hoheisel, G.-A., & Khot, L.R. (2020). The smart spray analytical system: Developing understanding of output air-assist and spray patterns from orchard sprayers. *Crop Protection*, *127*, 104977. <https://doi.org/10.1016/j.cropro.2019.104977>
- Chaitanya, P., Kotte, D., Srinath, A., & Kalyan, K.B. (2020). Development of smart pesticide spraying robot. *International Journal of Recent Technology and Engineering (IJRTE)*, *8*(5), 2193–2202. <https://doi.org/10.35940/ijrte.E6343.018520>
- Devi, G., Sowmiya, N., Yasoda, K., Muthulakshmi, K., & Balasubramanian, K. (2020). Review on application of drones for crop health monitoring and spraying pesticides and fertilizer. *Journal of Critical Reviews*, *7*(6).

- Gong, M., Zhang, H., & Liu, Z. (2020). An improved design and implementation of a range-controlled communication system for mobile phones. *Sensors*, *20*(17), 4997. <https://doi.org/10.3390/s20174997>
- Karmokar, A., Jani, N., Kalla, A., Harlalka, H., & Sonar, P. (2020). Inspection of concrete structures by a computer vision technique and an unmanned aerial vehicle. In *Proceedings of the 2020 International Conference on Computational Performance Evaluation (ComPE)* (pp. 338–343). IEEE. <https://doi.org/10.1109/ComPE49325.2020.9200107>
- Kim, K.-H., Kabir, E., & Jahan, S.A. (2017). Exposure to pesticides and the associated human health effects. *Science of the Total Environment*, *575*, 525–535. <https://doi.org/10.1016/j.scitotenv.2016.09.009>
- Kotkar, V.A., Ghute, A.A., Bhosale, S.A., & Hajare, K.T. (2021). An automatic pesticide sprayer to detect the crop disease using machine learning algorithms and spraying pesticide on affected crops. *Turkish Journal of Computer and Mathematics Education (TURCOMAT)*, *12*(1S), 65–72. <https://doi.org/10.17762/turcomat.v12i1S.1559>
- Lienkov, S., Myasishev, A., Banzak, O., Husak, Y., & Starynski, I. (2020). Use of rescue mode for UAV on the basis of STM32 microcontrollers. *International Journal of Advanced Trends in Computer Science and Engineering*, *9*(3), 3506–3513. <https://doi.org/10.30534/ijatcse/2020/156932020>
- Macák, M., Žitňák, M., & Nozdrovický, L. (2011). Using satellite navigation for seeding of wide-row and narrow-row crops. *Research in Agricultural Engineering*, *57*(Special Issue), S7–S13. <https://doi.org/10.17221/6/2011-RAE>
- Mahmud, M.S., Zahid, A., He, L., & Martin, P. (2021). Opportunities and possibilities of developing an advanced precision spraying system for tree fruits. *Sensors*, *21*(9), 3262. <https://doi.org/10.3390/s21093262>
- Mishra, A., & Behra, S. (2020). Design of an aerial manipulation system with robotic claw for search and rescue operations. In *2020 IEEE Bombay Section Signature Conference (IBSSC)* (pp. 224–230). IEEE. <https://doi.org/10.1109/IBSSC51096.2020.9332176>
- Mogili, U.R., & Deepak, B.B.V.L. (2018). Review on application of drone systems in precision agriculture. *Procedia Computer Science*, *133*, 502–509. <https://doi.org/10.1016/j.procs.2018.07.063>
- Mumtaz, Z., Ullah, S., Ilyas, Z., Aslam, N., Iqbal, S., Liu, S., Meo, J.A., & Madni, H.A. (2018). An automation system for controlling streetlights and monitoring objects using Arduino. *Sensors*, *18*(10), 3178. <https://doi.org/10.3390/s18103178>
- Nosirov, K., Begmatov, S., & Arabboev, M. (2020). Analog sensing and leap motion integrated remote controller for search and rescue robot system. *2020 International Conference on Information Science and Communications Technologies (ICISCT)*, 1–5. <https://doi.org/10.1109/ICISCT50599.2020.9351425>
- Patel, M.K. (2016). Technological improvements in electrostatic spraying and its impact to agriculture during the last decade and future research perspectives – A review. *Engineering in Agriculture, Environment and Food*, *9*(1), 92–100. <https://doi.org/10.1016/j.eaef.2015.09.006>
- Petranský, S.I., Drabant, Š., Ďudřák, J., Žikla, A., Grman, I., & Jablonický, J. (2003). Pressure in the hydraulic system of three point hitch of tractor equipped with electrical and mechanical control. *Research in Agricultural Engineering*, *49*(2), 37–43. <https://doi.org/10.17221/4950-RAE>
- Sánchez-Hermosilla, J., Rincón, V.J., Páez, F. C., Pérez-Alonso, J., & Callejón-Ferre, Á.-J. (2021). Evaluation of the effect of different hand-held sprayer types on a greenhouse pepper crop. *Agriculture*, *11*(6), 532. <https://doi.org/10.3390/agriculture11060532>
- Shamshiri, R.R., Weltzien, C., Hameed, I.A., Yule, I.J., Grift, T.E., Balasundram S.K., Pitonakova, L., Ahmad, D., & Chowdhary, G. (2018). Research and development in agricultural robotics: A perspective of digital farming. *Int J Agric & Biol Eng*, *11*(4). <https://doi.org/10.25165/j.ijabe.20181104.4278>
- Sobotka, J., Krejčí, J., & Blahovec, J. (2007). Equipment for the determination of dielectric properties of vegetable tissue during its mechanical loading. *Research in Agricultural Engineering*, *53*(4), 143–148. <https://doi.org/10.17221/1955-RAE>
- Su, H., Hu, Y., Karimi, H.R., Knoll, A., Ferrigno, G., & De Momi, E. (2020). Improved recurrent neural network-based manipulator control with remote center of motion constraints: Experimental results. *Neural Networks*, *131*, 291–299. <https://doi.org/10.1016/j.neunet.2020.07.033>
- Tkáč, Z., Jablonický, J., Abrahám, R., & Klusa, J. (2005). Measurement of pressure in hydraulics system of the ZTS 160 45 tractor. *Research in Agricultural Engineering*, *51*(4), 140–144. <https://doi.org/10.17221/4916-RAE>
- Wang, G., Lan, Y., Qi, H., Chen, P., Hewitt, A., & Han, Y. (2019a). Field evaluation of an unmanned aerial vehicle (UAV) sprayer: Effect of spray volume on deposition and the control of pests and disease in wheat. *Pest Management Science*, *75*(6), 1546–

1555. <https://doi.org/10.1002/ps.5321>

Wang, G., Lan, Y., Yuan, H., Qi, H., Chen, P., Ouyang, F., & Han, Y. (2019b). Comparison of spray deposition, control efficacy on wheat aphids and working efficiency in the wheat field of the unmanned aerial vehicle with boom sprayer and two conventional knapsack sprayers. *Applied Sciences*, *9*(2), 218. <https://doi.org/10.3390/app9020218>

Yarpuz-Bozdogan, N. (2018). The importance of personal protective equipment in pesticide applications in agriculture. *Current Opinion in Environmental Science & Health*, *4*, 1–4. <https://doi.org/10.1016/j.coesh.2018.02.001>

Yu, W., & Song, S. (2023). Design and experimentation of remote driving system for robotic speed sprayer operating in orchard environment. *ETRI Journal*, *45*(3), 479–491. <https://doi.org/10.4218/etrij.2022-0079>